

## Electrically tunable lens EL-16-40-TC (5D)

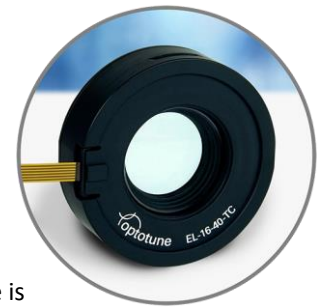

The EL-16-40-TC is a focus tunable lens based on Optotune's proprietary shape changing polymer lens technology. By applying an electric current, the lens curvature is adjusted within milliseconds from concave to convex, providing a focal power range of -2 dpt to +3 dpt. With actuators based on proven voice-coil technology, the EL-16-40-TC is extremely reliable and robust, well suited even for applications in harsh environments over large temperature ranges. To achieve good repeatability and focus stability, an integrated temperature sensor allows for in-situ compensation of temperature effects.

The EL-16-40-TC is available in its compact form for OEM integration but also with multiple thread adapters and a robust Hirose connector for industrial use, where the tunable lens can be easily combined with off-the-shelf imaging lenses.

Typical applications for this large aperture lens include machine vision, microscopy and ophthalmic devices.

### Lens specifications

Clear aperture	16	mm
Focal power range: (30°C, ±250 mA)	-2 to +3	dpt
Focal power @ 0 mA (25°C, typical)	0.5 +/-1.0	dpt
Repeatability in focal power mode	+/- 0.05 (small steps) +/- 0.1 (large steps)	dpt
Wavefront error @ 0 dpt (Optical axis vertical / horizontal)	<0.15 / <0.5 (class 1) <0.25 / <0.5 (class 2)	λ RMS @ 532 nm
Lens type	plano-concave to plano-convex	
Refractive index / Abbe number	$n_D = 1.30 / v = 100$	
Response time (typ. at 30°C, 0 to ±250 mA step)	5	ms
Settling time (typ. at 30°C, 0 to ±250 mA step)	25	ms
Lifecycles (10% - 90% sinusoidal)	> 1'000'000'000	
Operating temperature	-20 to 65	°C
Storage temperature	-40 to 85	°C
Weight	40	g

### Electrical specifications

Nominal control current	-250 to 250	mA
Absolute max. control current	-500 to 500	mA
Motor coil resistance @ 25°C	12	Ω
Power consumption (nominal)	0.7	W
Max power consumption (@ 250 mA)	2.8	W
Temperature sensor incl. EEPROM	STTS2004 (STMicroelectronics)	
Absolute maximum voltage (coil)	10	V
Absolute maximum voltage (memory & sensor)	4.3	V

## Overview of available standard products

Standard Product <sup>1,2</sup>	Tuning range	Top thread	Bottom thread
EL-16-40-TC-VIS-5D	-2 to +3 dpt	None	None
EL-16-40-TC-VIS-5D-M25.5	-2 to +3 dpt	M25.5x0.5 male	M40.5x0.5 female
EL-16-40-TC-VIS-5D-M26	-2 to +3 dpt	M26x0.706 male	M26x0.706 female
EL-16-40-TC-VIS-5D-M27	-2 to +3 dpt	M27x0.5 male	M40.5x0.5 female
EL-16-40-TC-VIS-5D-M30.5	-2 to +3 dpt	M30.5x0.5 male	M40.5x0.5 female
EL-16-40-TC-VIS-5D-C	-2 to +3 dpt	C-mount male	C-mount female
EL-16-40-TC-VIS-5D-M42	-2 to +3 dpt	M42x1 male	M42x1 female

1 All models are available with NIR coating or custom coating on request

2 Class-1 model with Wavefront error < 0.15  $\lambda$  RMS (vertical optical axis) available upon request.

## Liquid lens working principle

The working principle of the EL-16-40-TC is based on Optotune's well-established technology of shape-changing polymer lenses. The core that forms the lens contains an optical fluid, which is sealed off with an elastic polymer membrane as shown in Figure 1. An electromagnetic actuator (VCM) is used to exert pressure on the container and therefore changes the curvature of the lens. By changing the electrical current flowing through the coil of the actuator, the optical power of the lens is controlled.

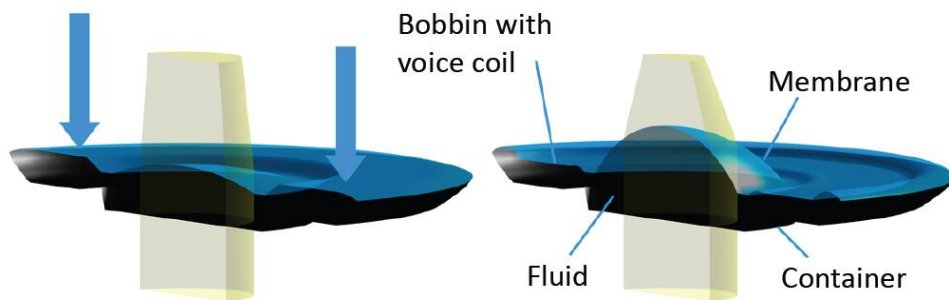

Figure 1: Working principle of the sealed lens container filled with an optical fluid and embedded in an EL-16-40-TC housing.

## Mechanical layout

The EL-16-40-TC comes with a black aluminum housing. The electrical connection and controller communication is established via a FFC cable at the side. In addition, customers can attach their own FFC cable via the ZIF-FFC-slide connector at the side of the housing. The relevant mechanical drawings are depicted in Figure 2.

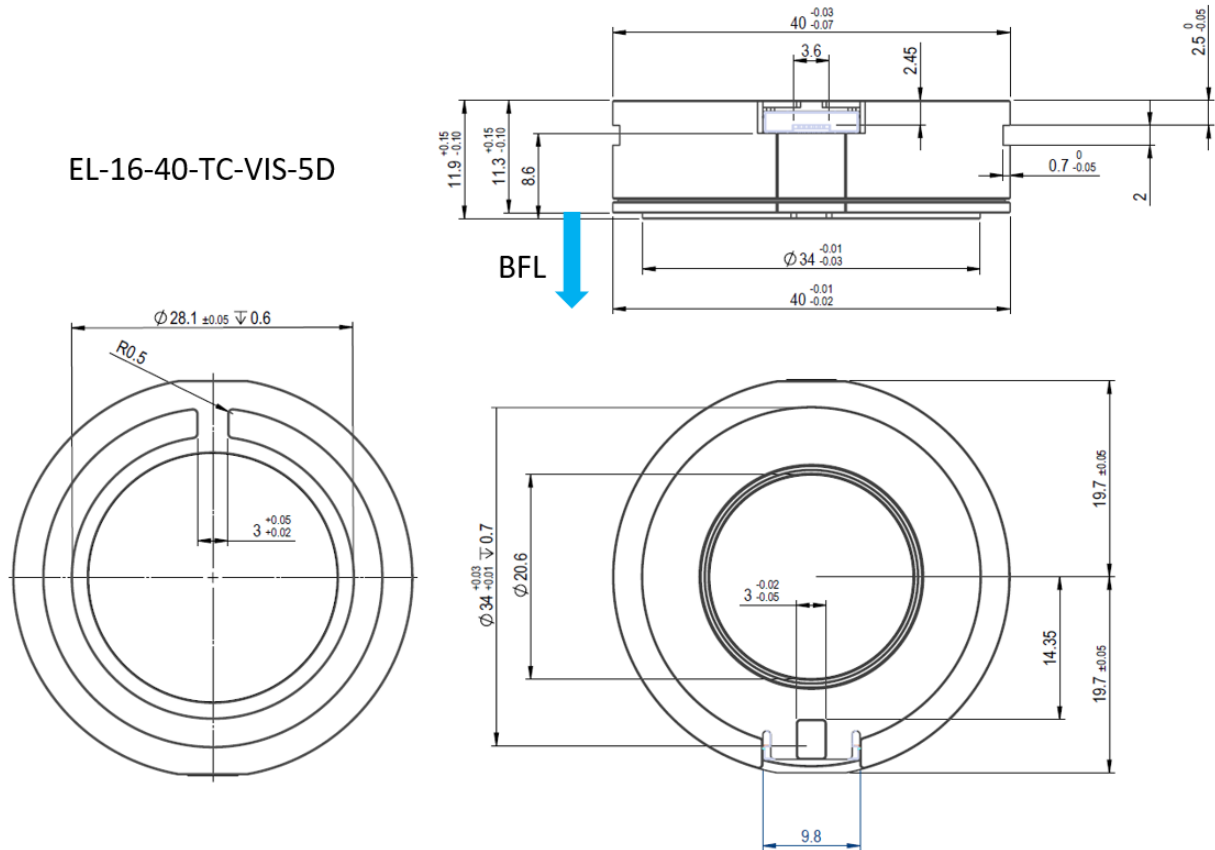

Figure 2: Mechanical drawing of the EL-16-40-TC in its most simple version, the EL-16-40-TC-VIS-5D without any thread adapters attached (unit: mm).

To allow maximum flexibility for the integration in an optical system, several adapter configurations are available, as seen in the overview of the standard product range. The EL-16-40-TC-VIS-5D-M42 is shown in the upper part of Figure 2. Here, the adapters provide a M42 male and female thread combination suitable for most M42-mount lenses and cameras. The top male thread is rotatable, can be extended along the z-axis by 3mm and is held in place with three setscrews (requiring 1.5mm Allen keys).

All other combinations –M25.5, –M26, –M27, –M30.5 and –C are realized by mounting the EL-16-40-TC in an M40.5x0.5 tube and offering different top and bottom adapters, which are also rotatable and lockable with one setscrew. As an example, the EL-16-40-TC-VIS-5D-C is shown in the lower part of Figure 2.

All adapter configurations come with an extension at the side, providing a 6-pin Hirose connector (HR10G-7R-6P), making it suitable for harsh environmental conditions. This can be seen on the right part of Figure 3.

### EL-16-40-TC-VIS-5D-M42

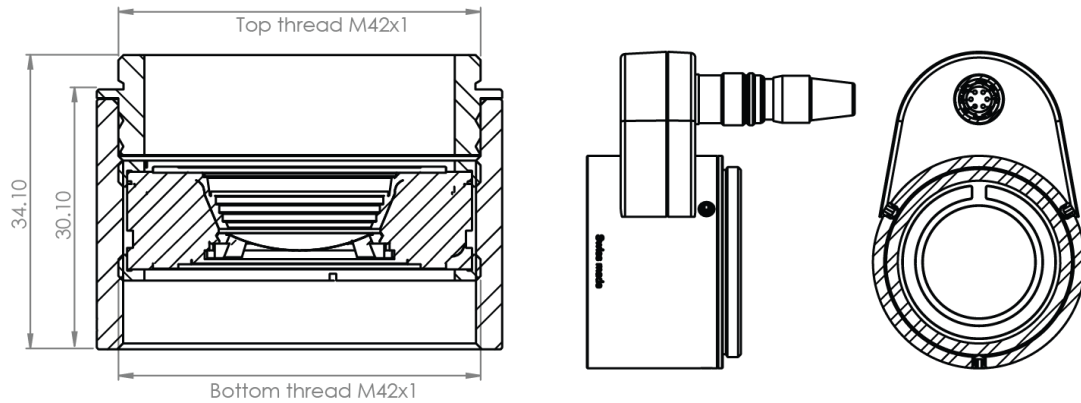

### EL-16-40-TC-VIS-5D-C (exemplary)

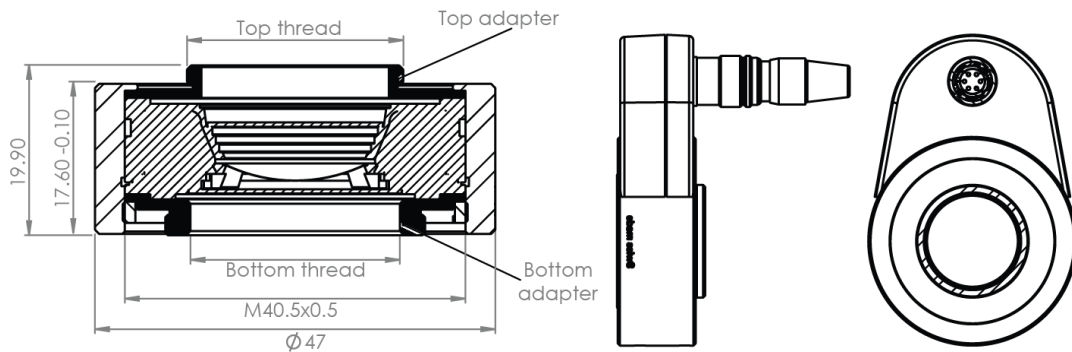
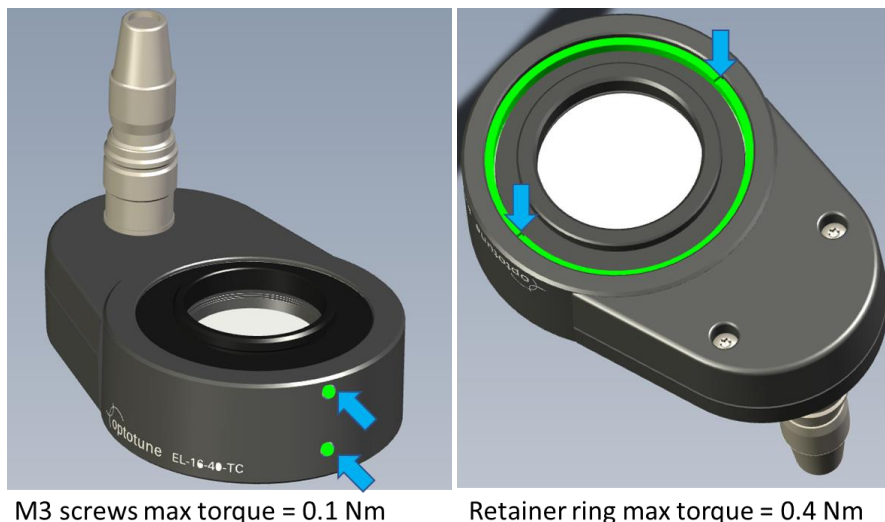

Figure 3: Mechanical drawing of EL-16-40-TC-VIS-5D-M42 and EL-16-40-TC-VIS-5D-C, whereas the latter example also represents the combinations –M25.5, –M26, –M27, –M30.5 (unit: mm).

The design features two M3 screws on the side, which are used to lock the position of the thread adapters. The upper M3 screw can be loosened to freely rotate the Hirose connector against the top thread if needed. The lower M3 screw holds in place the bottom thread. Each M3 screw can be tightened with a maximum torque of 0.1 Nm. It is recommended to first loosen both M3 screws, tighten the retainer ring, then tighten the M3 screws.



M3 screws max torque = 0.1 Nm

Retainer ring max torque = 0.4 Nm

**Attention: The distance from flange to bottom cover glass of the EL-16-40-TC-VIS-5D-C is 4.8mm. Please make sure not to screw in any C-mount lenses with protruding optics as they may scratch or even crack the glass.**

## Electrical connection

The electrical connection of the EL-16-40-TC without adapters consists of a FPC flex cable with 6 pins suitable for Molex connector no. 503480-0600 or equivalent. Two pins are for the coil of the lens, the other four pins are for the I<sup>2</sup>C connection to the temperature sensor and EEPROM. The I<sup>2</sup>C addresses are 0x18 and 0x50, respectively.

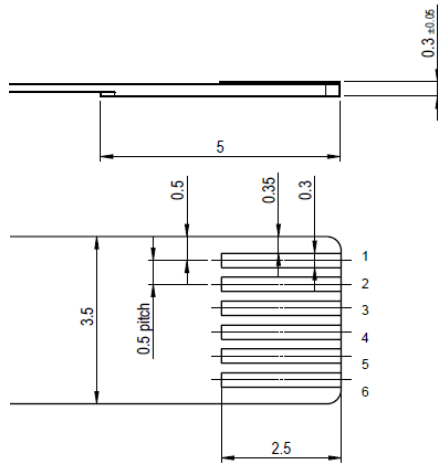

Pin out: EL-16-40-TC		
Position	Function	Value
1	GND	-
2	Max. control current -	-500 to 500 mA
3	Max. control current +	-500 to 500 mA
4	I <sup>2</sup> C SDA	Digital signal
5	I <sup>2</sup> C SCL	Digital signal
6	Vcc	3.3 V

Figure 4: Electrical flex connections of the EL-16-40-TC basic version without adapters.

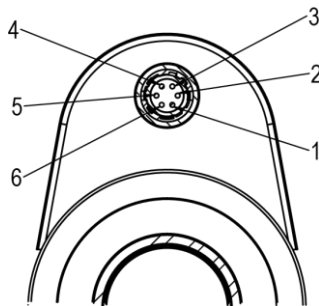

Pinning Hirose connector HR10G-7R-6PB(73)		
Position	Function	Sensor pins
1	Max. control current +	-
2	Max. control current -	-
3	Gnd	1-4
4	Power	8
5	I <sup>2</sup> C SCL	6
6	I <sup>2</sup> C SDA	5

Figure 5: Electrical connections of the Hirose connector. The pinout is the same for all adapter versions.

## Focal power versus current

The focal power of the EL-16-40-TC increases with positive and decreases with negative current as shown in Figure 6. When driving the lens up to absolute maximum control current, the tuning range increases further but significant heat generation must be considered.

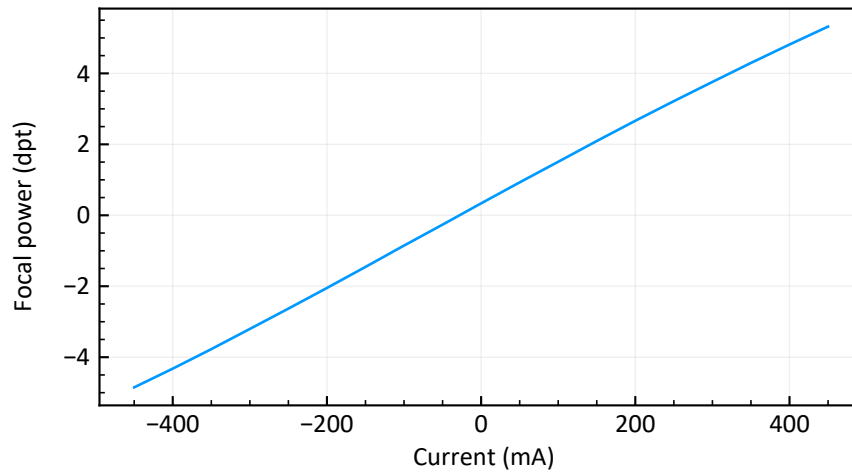

Figure 6: Typical data showing the relation between focal power (in diopters) and electrical current.

## Transmission

Both the optical fluid and the membrane material are highly transparent in the range of 400 to 2500 nm. As the membrane is elastic it cannot be coated using standard processes, hence a reflection of 3 – 4% is to be expected. Cover glasses can be coated as desired. Figure 7 shows the transmission spectrum for the standard broad-band coatings.

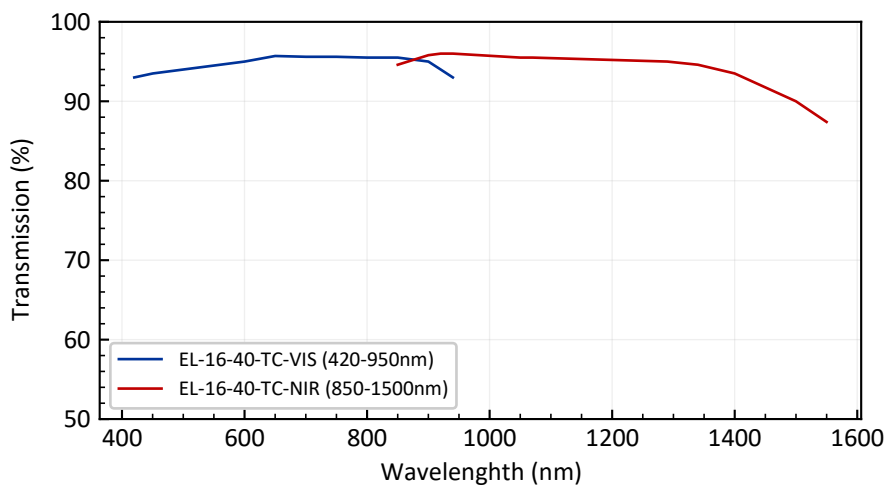

Figure 7: Transmission spectra of EL-16-40-TC standard VIS & NIR coating.

## Wavefront quality

Figure 8 shows the typical wavefront error as a function of focal power. The wavefront quality varies from lens to lens and can be specified differently upon request, whereas the current standard specification is  $0.15 \lambda$  RMS for class 1 and  $0.25 \lambda$  RMS for class 2 lenses, respectively. When using the lens standing upright (optical axis horizontal) a Y-coma term must be added resulting in a wavefront error in the order of  $0.5 \lambda$ . The gravity induced Y-coma term of Optotune's tunable lenses generally depends on the clear aperture, the density of the liquid used and the mechanical properties of the membrane.

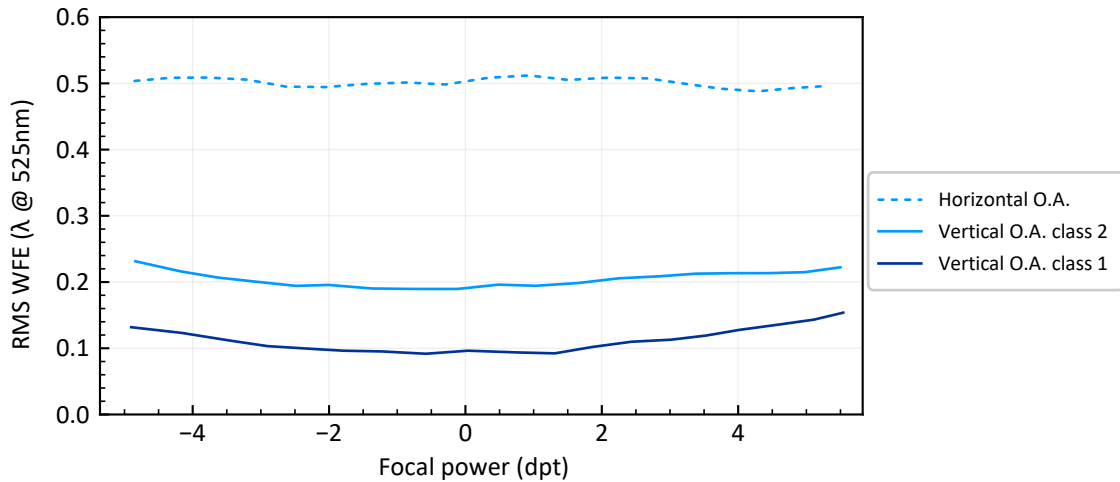

Figure 8: Typical wavefront error of the EL-16-40-TC vs focal power with optical axis vertical and horizontal (@525nm, measured over 80% of the clear aperture, defocus, tilt and sphere excluded).

## Response time

The rise time when applying a current step is about 5 ms. However, it takes about 25 ms until the higher order oscillations of the lens have fully settled. Figure 9 shows the optical response for several current steps measured at room temperature. The settling time can be reduced by typically up to 50% with appropriate signal conditioning.

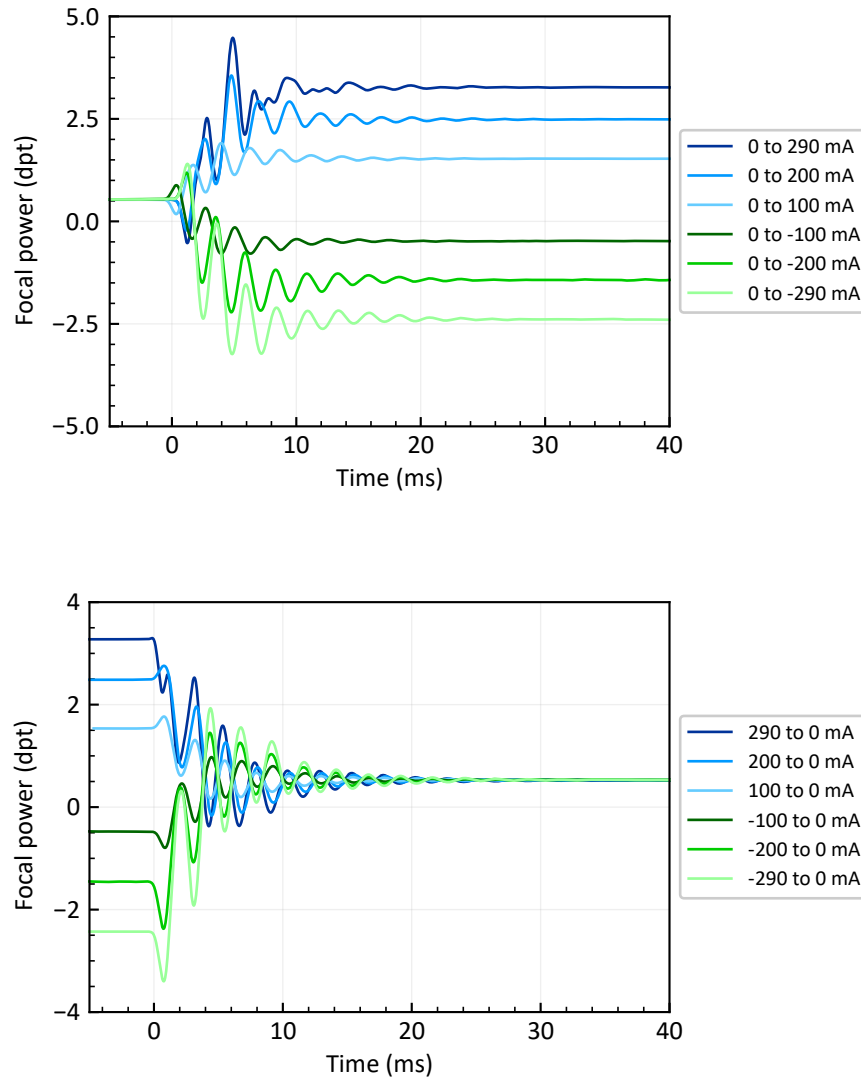

Figure 9: Typical optical response of the EL-16-40-TC-VIS-5D for several current steps. The upper plot shows a series of steps from low to high current and the lower plot for steps from high to low current.

The frequency response over a broad range is presented in Figure 10, showing a resonance peak at 400 Hz. Note that this resonance is from a higher order mode, which can generally not be used for imaging over the entire clear aperture. When applying a current step, it is recommended to damp frequencies above 200 Hz range by using a low pass filter. This avoids excitation oscillations as seen in Figure 9.



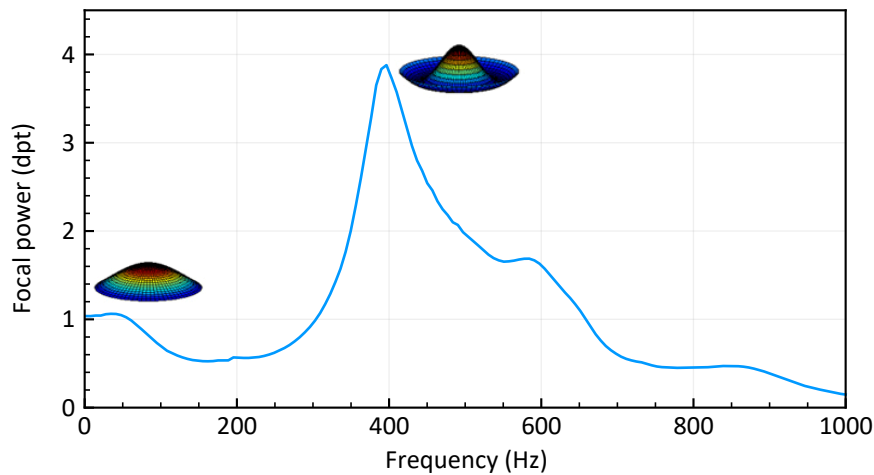

Figure 10: Typical frequency response of the EL-16-40-TC. The driving amplitude is -50 to 50 mA.

### Temperature effects

Residual temperature effects influence the long-term drift of optical power stated in the specification table. These temperature effects are quantified by the temperature sensitivity  $S$  (dpt/°C), giving the change in optical power per degree Celsius. As shown in Figure 11, there is an almost linear dependence of  $S$  with optical power. Generally, temperature effects can be minimized when the EL-16-40-TC is thermally connected to a heat sink. The mounting itself can be used as a heat sink. Large mass and high thermal conductivity of the material dissipates the heat more efficiently. Optotune's Lens Controllers and Gardasoft's TR-CL180 offer automatic thermal compensation to achieve a repeatability of typically  $\pm 0.05$  dpt for small and  $\pm 0.1$  dpt for large focus steps.

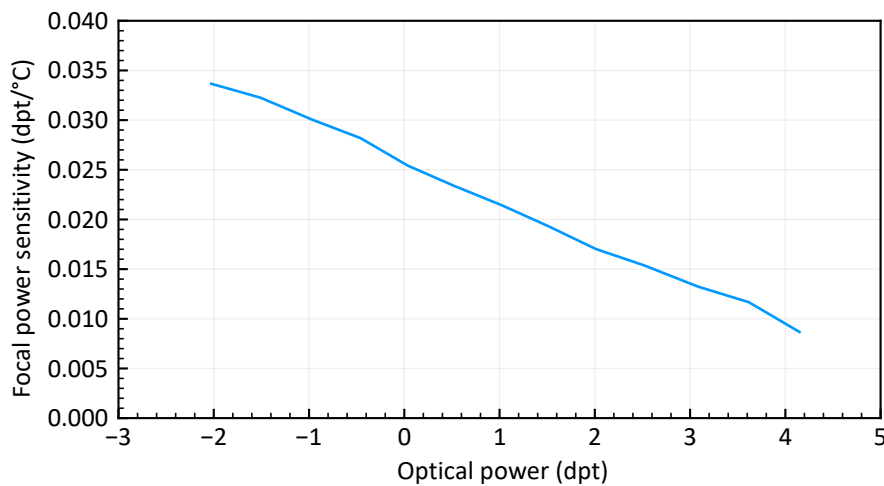
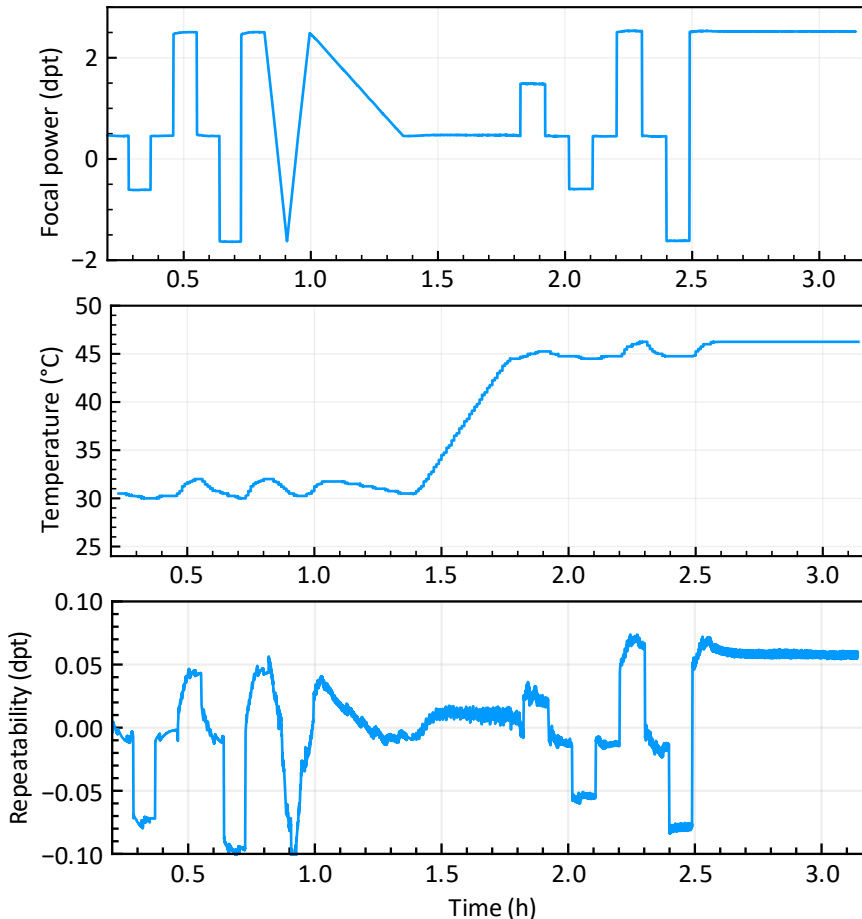

Figure 11: Temperature sensitivity as a function of focal power.

## Repeatability measurement

To verify the repeatability under demanding conditions we perform a long-term measurement using Optotune's Lens Driver 4. During the measurement which lasts for about 3 hours, we change the optical power of the lens and environmental temperature significantly.



The optical power is varied in different patterns, e.g. large and small steps, fast and slow ramps. The x-axis represents the time in hours, as for the other plots.

After about 1.5 hours, the temperature is increased by 15°C to 45°C.

The error of optical power represents the repeatability and is the difference between measured and set focal power. The repeatability remains within +/- 0.1 dpt.

Figure 12: Repeatability measurement over a time span of about 3 hours. Optical power and environmental temperature are varied over a broad range while the error between measured and set optical power remains small.

The actual optical power is measured on the Shack Hartmann sensor in parallel. The repeatability is inferred by calculating the difference between the actual (measured) and set optical power. The resulting errors remain within +/- 0.1 dpt.

## Optical layout

Zemax simulations to model the EL-16-40 lens series within an optical design are available at this [link](#).

## Autofluorescence, birefringence & polarization effects

The EL-16-40-TC is neither auto-fluorescent, birefringent or in any other way polarization dependent.

## Safety and compliance

The product fulfills the RoHS and REACH compliance standards. The customer is solely responsible to comply with all relevant safety regulations for integration and operation.

For more information on optical, mechanical, and electrical parameters, please contact [sales@optotune.com](mailto:sales@optotune.com)

## Packaging

The EL-16-40 industrial version is available in single units packaged in a box. The EL-16-40 OEM version is available in single units packaged in a membrane box or in trays of 25 units each.

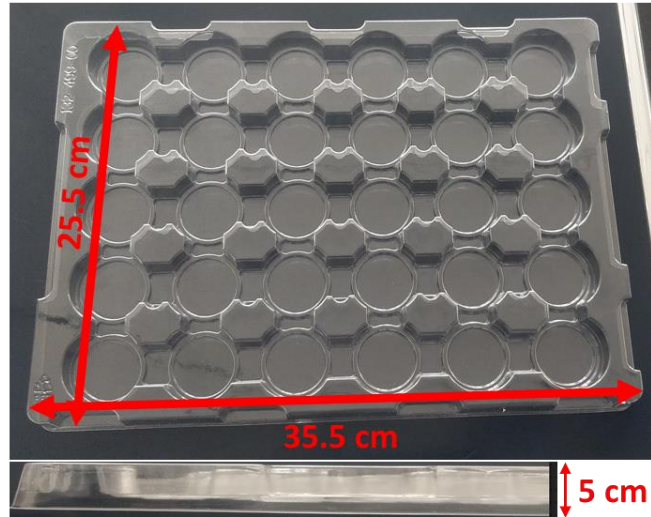

Figure 13: Sizes of the 25 units tray for the OEM version.

## Ordering information for EL-16-40-TC

For custom versions, please use the following concept for part numbers:

**EL-16-40-TC-AR-DPT-CL-THR**

AR = VIS: 420 – 950nm  
NIR: 850 – 1500nm

DPT = 5D: 5 diopter range  
20D: 20 diopter range

CL = 1: class 1 specification for wavefront error

THR = C: C-mount thread  
M25.5: M25.5x0.5 thread  
M26: M26x0.706 thread  
M27: M27x0.5 thread  
M30.5: M30.5x0.5 thread  
M42: M42x1 thread