

FLIR BLACKFLY S[®]

P/N: BFS-U3-16S2, USB3 VISION



SMALL PACKAGE, POWERFUL RESULTS

The Blackfly S combines the newest CMOS image sensors with our new and intuitive Spinnaker software development kit. The many new advanced features are designed to meet your complex imaging needs and speed up development time.

KEY FEATURES

- Leverage the latest CMOS sensors and new on-camera image processing features. Harness increased flexibility, powerful auto-exposure controls and robust transformations.
- Improve cycle time using advanced camera controls and programmable sequencer, chunk data, event notification, counters, timers and logic blocks
- Accelerate your time to market with GenCam API, GUI API library and detailed API logging and comprehensive documentation

USB VISION GEN<i>CAM

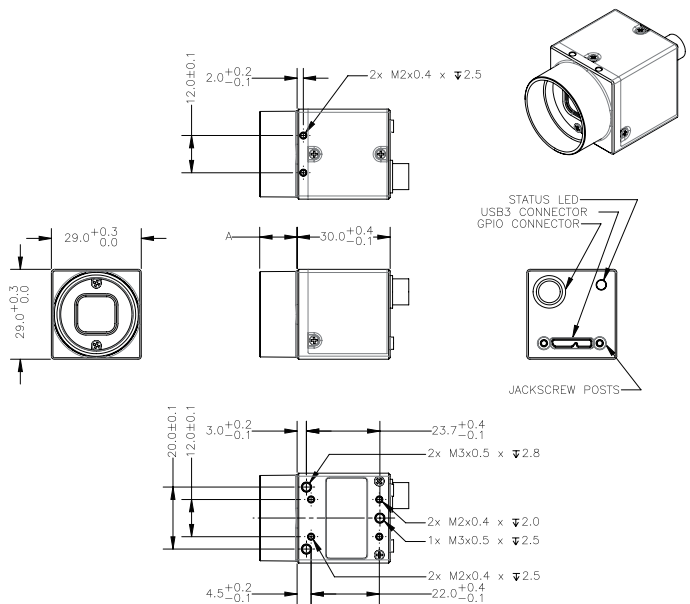

Specifications

	BFS-U3-16S2M-CS	BFS-U3-16S2C-CS
Resolution	1440 x 1080	
Frame Rate*	226FPS	
Megapixels	1.6 MP	
Chroma	Mono	Color
Sensor	Sony IMX273, CMOS, 1/2.9"	
Readout Method	Global shutter	
Pixel Size	3.45 μ m	
Lens Mount	CS-mount	
ADC	10-bit, and 12-bit	
Minimum Frame Rate**	1 FPS	
Gain Range**	0 to 47 dB	
Exposure Range**	4 μ s to 30 s	
Acquisition Modes	Continuous, Single Frame, Multi Frame	
Partial Image Modes	Pixel binning, decimation, ROI	
Image Processing	Gamma, lookup table, and sharpness	Color correction matrix, gamma, lookup table, saturation, and sharpness
Sequencer	Up to 8 sets using 2 features	
Image Buffer	240 MB	
User Sets	2 user configuration sets for custom camera settings	
Flash Memory	6 MB non-volatile memory	
Opto-isolated I/O	1 input, 1 output	
Non-isolated I/O	1 bi-directional, 1 input	
Auxiliary Output	3.3 V, 120 mA maximum	
Interface	USB 3.1 Gen 1	
Power Requirements	8 - 24 V via GPIO or 5 V via USB3 interface	
Power Consumption	3 W maximum	
Dimensions/Mass	29 mm x 29 mm x 30 mm / 36 g	
Machine Vision Standard	USB3 Vision v1.0	
Compliance	CE, FCC, KCC, RoHS, REACH. The ECCN for this product is: EAR099.	
Temperature	Operating: 0°C to 50°C Storage: -30°C to 60°C	
Humidity	Operating: 20% to 80% (no condensation) Storage: 30% to 95% (no condensation)	
Warranty	3 years	

*Frame rates are measured with Device Link Throughput Limit of 380 MBps and Acquisition Frame Rate disabled. Values are rounded down to whole numbers.

**Values are the same in binning and no binning modes.

FLIR Integrated Imaging Solutions

CANADA

12051 Riverside Way
Richmond, BC, Canada
V6W 1K7
T: +1 866.765.0827 (toll free)
T: +1 604.242.9937
F: +1 604.242.9938
E: mv-sales@flir.com
www.flir.com/mv

USA

T: +1 866.765.0827 (toll free)
E: mv-na-sales@flir.com

EUROPE

T: +49 7141 488817-0
F: +49 7141 488817-99
E: mv-eusales@flir.com

CHINA

T: +86 10 8215 9938
F: +86 10 8215 9936
E: mv-chinasales@flir.com

ASIA

E: mv-asiasales@flir.com

For a full list of international distributors and offices visit www.flir.com/contact-us

©2018 FLIR® Integrated Imaging Solutions Inc. All rights reserved. Names and marks appearing on the products herein are either registered trademarks or trademarks of FLIR® Systems, Inc. and/or its subsidiaries.